

EXAMPLE
DRAFT
Stormwater Treatment Facilities
Operation and Maintenance Plan
for a Residential Subdivision Project
Whispering Pines Lane
Anytown, USA

30 September 2015

XYZ Corporation
Jane Jones, 805-555-1212

This example prepared by Dan Cloak Environmental Consulting
for County of Santa Barbara Project Clean Water
to assist users of the *Stormwater Technical Guide*

Table of Contents

I.	Introduction	3
I.A.	Site Description	3
II.	Designation of Responsible Individuals	3
II.A.	Designated Contacts for Operation and Maintenance	3
II.A.1.	Bioretention Facility 1	3
II.A.2.	Bioretention Facility 2	3
II.B.	Off-Hours or Emergency Contact(s)	3
II.B.1.	Bioretention Facility 1	3
II.B.2.	Bioretention Facility 2	4
II.C.	Initial Training of Responsible Individuals	4
III.	Facilities to be Maintained	4
III.A.	Facility Descriptions	4
III.A.1.	Bioretention Facility #1	4
III.A.2.	Bioretention Facility #2	5
III.B.	Facility Construction Details	5
IV.	Maintenance Activities	5
IV.A.	General Maintenance Rules	5
IV.B.	Maintenance Schedule	5
IV.B.1.	Routine Activities	5
IV.B.2.	Following Significant Rain Events	6
IV.B.3.	Prior to the Start of the Rainy Season	6
IV.B.4.	Annually During Winter	6

Figures

Figure 1.	Bioretention Cross Section (Schematic)	4
-----------	----------------------------------------	---

Attachments

Stormwater Control Plan

Stormwater Control Plan Exhibit

As-Built Drawings (in Final O&M Plan)

I. Introduction

I.A. Site Description

The site is flat and abuts Arterial Street. Total site area is 3 acres, including nine single-family residences and a connecting street with sidewalks.

Soils are silty sands (Hydrologic Soil Group "B").

Stormwater treatment is provided by two bioretention facilities.

II. Designation of Responsible Individuals

The two bioretention facilities will each be located on a jointly owned parcel, with easy access to the public street. Owners of parcels 1, 2, 3, and 4 will jointly own the parcel on which Bioretention Facility 1 is located, and will be jointly responsible for the maintenance of that facility, subject to provisions in the subdivision map and Conditions, Covenants, and Restrictions (CC&Rs) recorded against the subdivision. Similarly, owners of parcels 5, 6, 7, 8, and 9 will jointly own the parcel on which Bioretention Facility 2 is located, and will be jointly responsible for the maintenance of that facility.

XYZ Corporation will be responsible for maintenance of the facilities until all nine properties have been transferred to new owners, the new owners have engaged licensed landscape contractors to maintain each of the facilities, and the owners of each of the facilities have selected one owner to be the designated contact for that facility. The owners of parcels 1, 2, 3, and 4 will engage a licensed landscape contractor to maintain Bioretention Facility 1 and the owners of parcels 5, 6, 7, 8, and 9 will engage a licensed contractor to maintain Bioretention Facility 2.

II.A. Designated Contacts for Operation and Maintenance

II.A.1. Bioretention Facility 1

[name, title or position]

[address]

[telephone and email]

II.A.2. Bioretention Facility 2

[name, title or position]

[address]

[telephone and email]

II.B. Off-Hours or Emergency Contact(s)

This is expected to be the contractor(s) selected by the owners of the individual lots.

II.B.1. Bioretention Facility 1

[name, title or position]

[address]

[telephone and email]

II.B.2. Bioretention Facility 2

[name, title or position]

[address]

[telephone and email]

II.C. Initial Training of Responsible Individuals

Following completion of construction, the bioretention facilities will be maintained by XYZ Corporation's contractor for two years. During this time, XYZ Corporation's contractor will provide written guidelines and conduct at least two on-site training sessions attended by the new owners' contractor(s).

III. Facilities to be Maintained

III.A. Facility Descriptions

There are two bioretention facilities on-site. Each has the following features:

- Surrounded by a concrete curb. Where adjacent to pavement, curbs are thickened and an impermeable vertical cutoff wall protects the pavement subgrade from moisture intrusion.
- Each layer built flat and level. See Figure 1.
- Class 2 permeable, Caltrans specification 68-2.02F(3); depth as shown in as-built drawings
- 18 inches sand/compost mix
- 4 in. dia. PVC SDR 35 perforated pipe underdrain, installed with the invert at the top of the Class 2 permeable layer with holes facing down, and connected to the overflow structure at that same elevation
- 6-inch-deep reservoir between top of soil elevation and overflow grate elevation
- Concrete drop inlet with frame overflow structure, with grate set to specified elevation, connected to storm drain in Main Street
- Plantings
- Irrigation system with drip emitters and "smart" irrigation controllers
- Sign identifying the facility as a stormwater treatment facility.

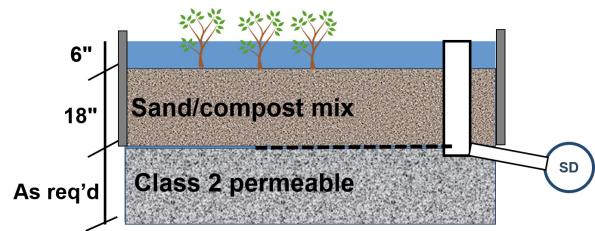

Figure 1. Bioretention Cross-Section (schematic)

III.A.1. Bioretention Facility #1

See the attached Stormwater Control Plan Exhibit. Bioretention Facility #1 receives drainage from the front portion of the roofs, and from the driveways, of Lots 1, 2, 3, and 4. It also receives drainage from the portion of the Whispering Pines Lane fronting these properties, from the crown to curb. Runoff collects in the curb and drains to an inlet and duct beneath the sidewalk, which conveys flows

to the facility. The facility overflow and underdrain is connected via a [specify pipe] to the City's storm drain system at a drop inlet near the corner of the site.

III.A.2. Bioretention Facility #2

See the attached Stormwater Control Plan Exhibit. Bioretention Facility #1 receives drainage from the front portion of the roofs, and from the driveways, of Lots 5, 6, 7, 8, and 9. It also receives drainage from the portion of the Whispering Pines Lane fronting these properties, from the crown to curb. Runoff collects in the curb and drains to an inlet and duct beneath the sidewalk, which conveys flows to the facility. The facility overflow and underdrain is connected via a [specify pipe] to the City's storm drain system at a drop inlet near the corner of the site.

III.B. Facility Construction Details

[To be added following construction]

[Attach As-Built Drawings to Final O&M Plan]

IV. Maintenance Activities

IV.A. General Maintenance Rules

At no time will synthetic pesticides or fertilizers be applied, nor will any soil amendments, other than aged compost mulch or sand/compost mix, be introduced. The top of soil surface will be maintained at or near the design elevation throughout. Irrigation systems will be maintained to conserve water while maintaining plant health.

Although it is unlikely to be needed, if plants are not thriving compost tea may be applied at a recommended rate of 5 gallons mixed with 15 gallons of water per acre, up to once per year between March and June. Compost tea will not be applied when temperatures are below 50°F or above 90°F or when rain is forecast within the next 48 hours.

The following may be applied for pest control if needed:

- Beneficial nematodes
- Safer® products
- Neem oil

IV.B. Maintenance Schedule

The three bioretention facilities will be maintained on the following schedule at a minimum.

IV.B.1. Routine Activities

The facilities will be examined daily for visible trash during regular policing of the site, and trash will be removed. Any graffiti, vandalism, or other damage will be noted and addressed within 48 hours.

The planted areas will be weeded by hand approximately monthly. At this time plants will be inspected for health and the irrigation system will be turned on manually and checked for any leaks or broken lines, misdirected spray patterns etc. Any dead plants will be replaced.

IV.B.2. Following Significant Rain Events

A significant rain event will be considered to be one that produces approximately a half-inch or more rainfall in a 24-hour period. Within 24 hours after each such event, the following will be conducted:

The surface of the facility will be observed to confirm there is no ponding.

- Inlets will be inspected, and any accumulations of trash or debris will be removed.
- The surface of the mulch layer will be inspected for movement of material. Mulch will be replaced and raked smooth if needed.

IV.B.3. Prior to the Start of the Rainy Season

In September or each year, facility inlets and outlets will be inspected to confirm there is no accumulation of debris that would block flow. If not previously addressed during monthly maintenance, any growth and spread of plantings that blocks inlets or the movement of runoff across the surface of the facility will be cut back or removed.

IV.B.4. Annually During Winter

Once, in December - February of each year, vegetation will be cut back as needed, debris removed, and plants and mulch replaced as needed. The concrete work will be inspected for damage. The elevation of the top of soil and mulch layer will be confirmed to be consistent with the design elevation and with the design 6-inch reservoir depth.

Stormwater Control Plan Exhibit Whispering Pines Lane

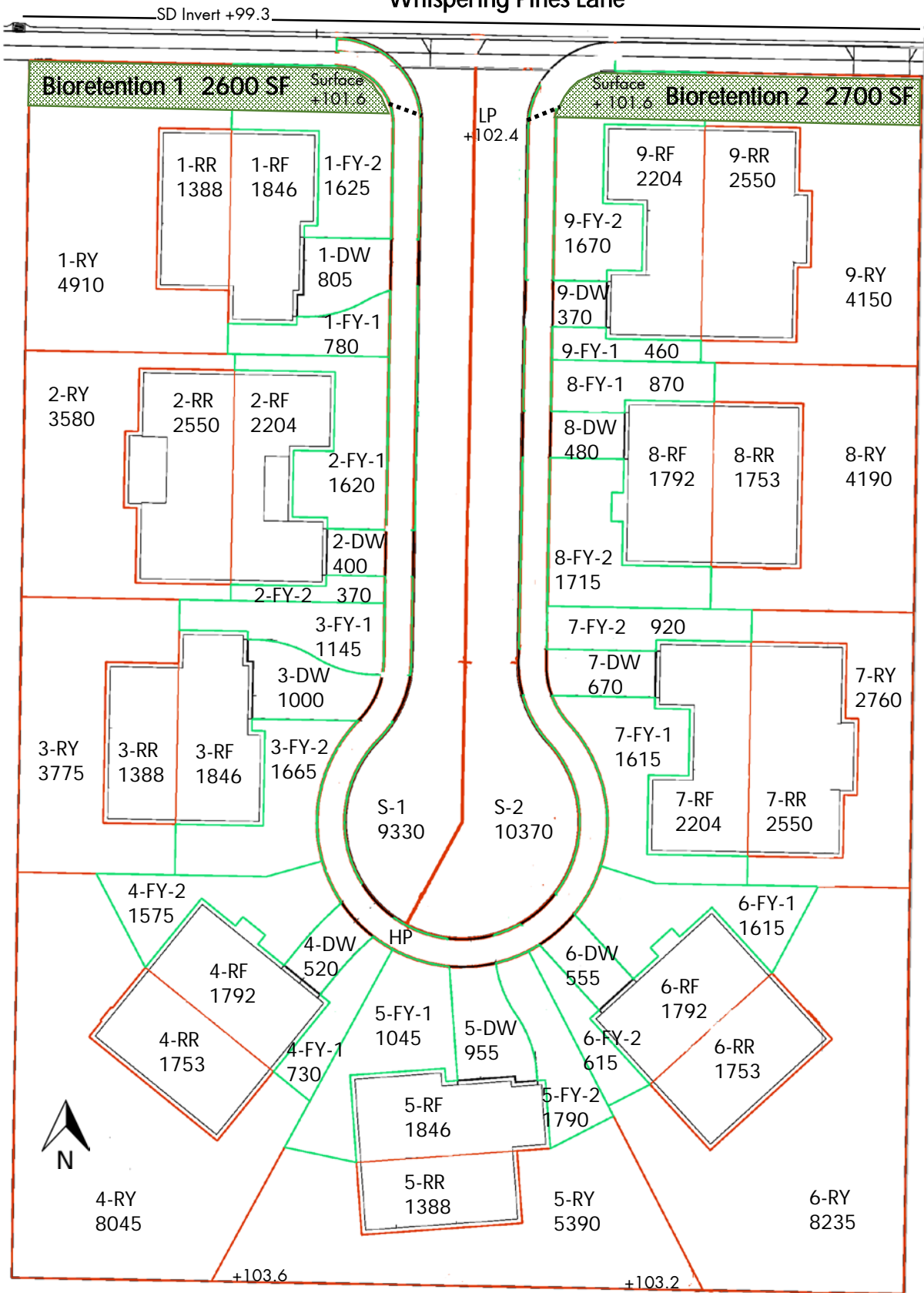

50 feet